

WMZ SERIES DOUBLE SECTION WALL MOUNTED CABINET

6U, 9U, 12U, 15U AND 18U SIZES



Morrell designed and engineered WMZ Series as the solution to house rack mount equipment for cabling, telecommunications, IT, industrial and home installations.

» FEATURES

Double section structure

Swing frame allows the cabinet to swing away from the wall for easy access to equipment and cabling.

Sturdy welded construction

Fully welded and assembled.

Optional doors

You choice of toughened glass or vented door.

Loading Capacity

Loading capacity up to 60kg.

Big door-opening angle

Over 180 degrees turning angle of front door and over 90 degrees for rear door.



Welded structure can be easy assembled.



Slots in back ensure convenient and quick wall mounting.



120mm*120mm fans can be preinstalled on the top cover. Relevant fan tray suit to all WMX, WMY, and WMZ wall mounted cabinets. (Brush panel is optional for cable entry panel.)



Swing frame allows the cabinet to swing away from the wall for easy access to equipment and cabling.



Removable side panels simplify your installation of accessories and monitoring of IT equipment.



L-shaped spring pin make it fast to install front door to the frame and easily to change door opening direction.

» COMPONENTS OF WMZ SERIES DOUBLE SECTION WALL MOUNTED CABINET

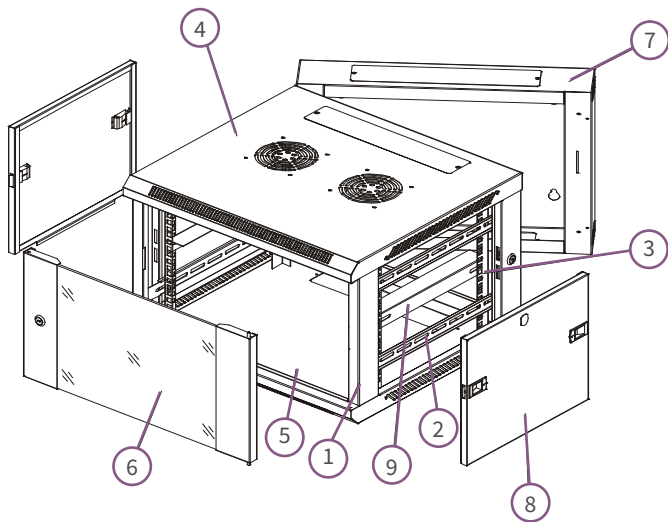

S/N	Name	Quantity
1	Frame	1
2	Horizontal bracket	4
3	Vertical rail	4
4	Top cover	1
5	Bottom panel	1
6	Front door	1
7	Rear swing	1
8	Side panel	2
9	L-shaped bracket	2

» OPTIONAL DOORS-STRUCTURE DRAWING

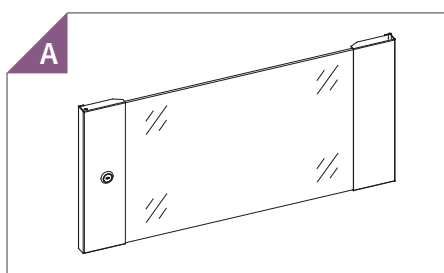

Tempered Glass Door
Lock: Small Round Lock

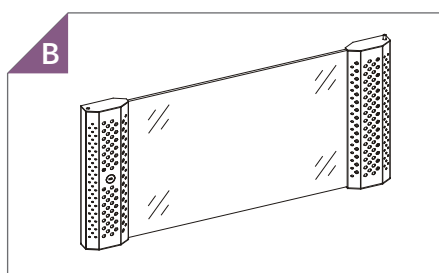

Tempered Glass Door, with Vented Holes
Lock: Small Round Lock

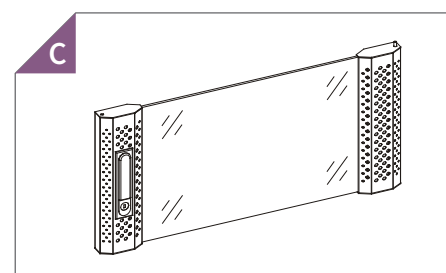

Tempered Glass Door, with Vented Holes
Lock: Spring Lock

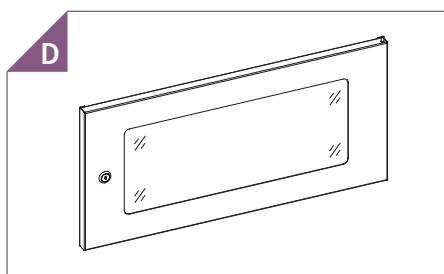

Tempered Glass Door
Lock: Small Round Lock

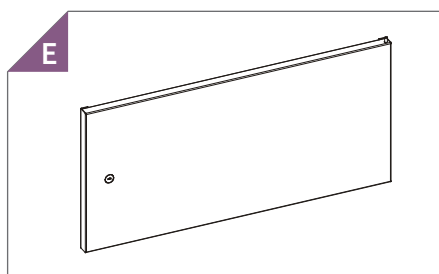

Solid Iron Door
Lock: Small Round Lock

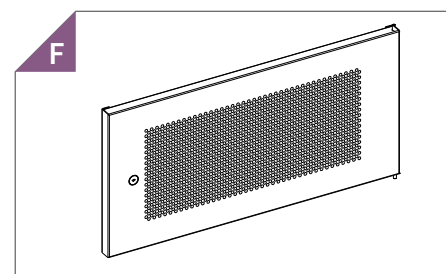

Vented Front Door
Lock: Small Round Lock

» MAIN DIMENSION

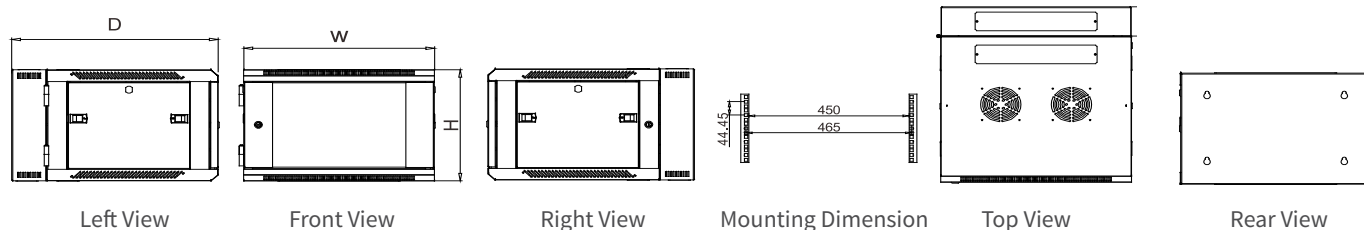

» HOW TO DEFINE OUR MODEL

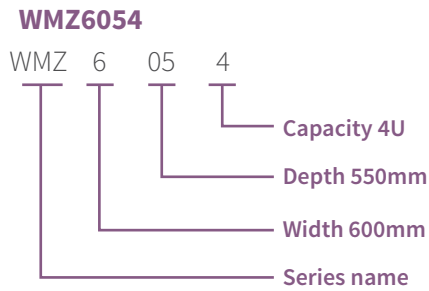

» SPECIFICATIONS

Model	Capacity (U)	Dimension W x D x H(mm)	BU Packing Dimension		KD Packing Dimension		
			W*D*H(mm)	Volume (CBM)	Carton A W x D x H(mm)	Carton B W x D x H(mm)	Volume (CBM)
FO-REP/WMZ6054	4U	600 x 550 x 280	620 x 575 x 305	0.109	620 x 180 x 570		0.064
FO-REP/WMZ6056	6U	600 x 550 x 370	620 x 575 x 395	0.141	620 x 110 x 570	620 x 130 x 390	0.07
FO-REP/WMZ6059	9U	600 x 550 x 505	620 x 575 x 525	0.187	620 x 110 x 570	620 x 130 x 525	0.081
FO-REP/WMZ60512	12U	600 x 550 x 640	620 x 575 x 665	0.237	620 x 110 x 570	620 x 130 x 660	0.092
FO-REP/WMZ60515	15U	600 x 550 x 780	620 x 575 x 805	0.287	620 x 110 x 570	620 x 130 x 800	0.103
FO-REP/WMZ60518	18U	600 x 550 x 910	620 x 575 x 935	0.333	620 x 110 x 570	620 x 130 x 930	0.114
FO-REP/WMZ60520	20U	600 x 550 x 1000	620 x 575 x 1020	0.364	620 x 110 x 570	620 x 130 x 1020	0.121

Note:

Package: BU - Build up
Include KD-Knocked Down

Color:

RAL9005	RAL7035

Material:

SPCC Cold Rolled Steel.